

A3 工业安全带使用说明

A3 FULLBODY SITHARNNESS

Safety precautions

Warning

This manual explains how to use the equipment and only appropriate techniques and uses are described. Warning signs tell the potential risks but they don't cover everything. Please read every each warning carefully and use your equipment properly. Any misuse might lead to danger. If you are in doubt, please contact XINDA.

	Risk of severe injury or death
	Risk of accident or harm
	Appropriate way of use
	Incorrect way of use

Categorization

A3 PRO
HH-9589



A3
HH-9590

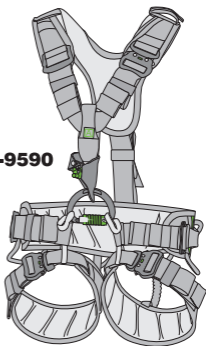

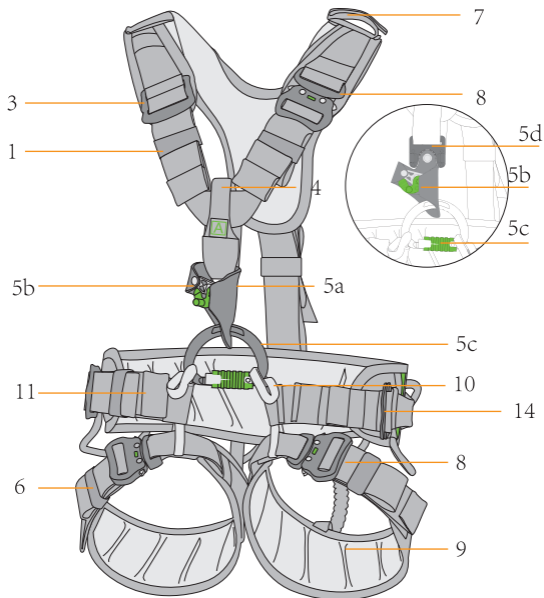

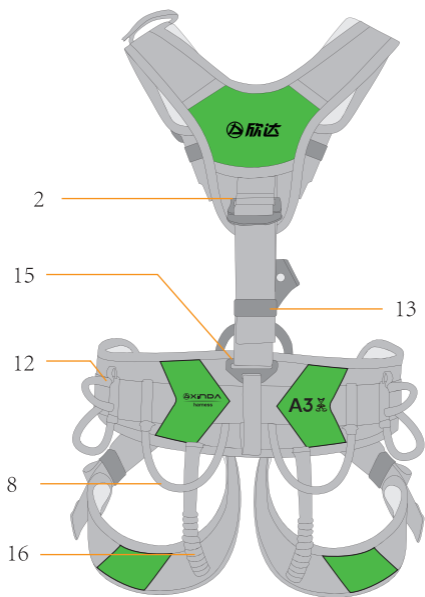

ISO9001 Standards Complied



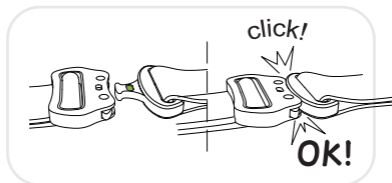
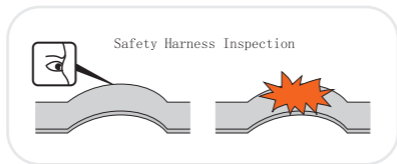

Front

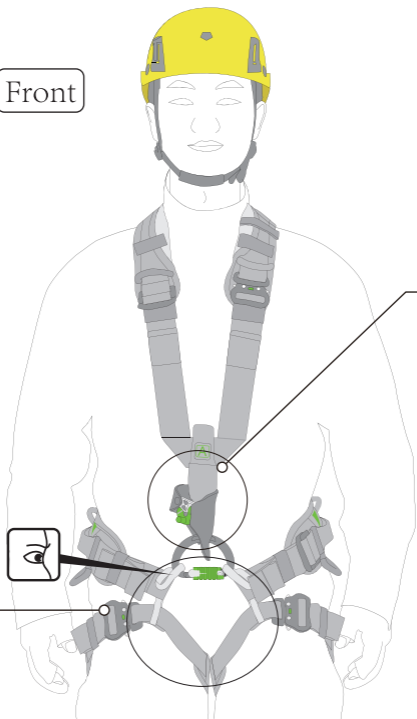

A3 PRO
HH-9589



A3
HH-9590

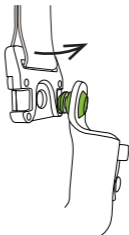
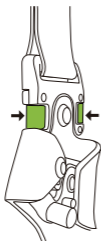

Fall-arrest harness

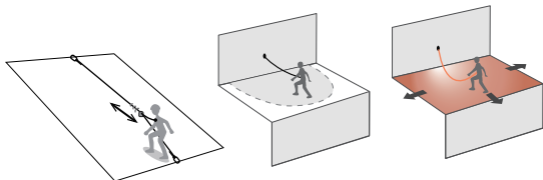
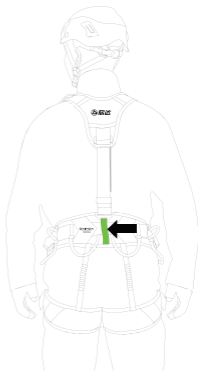
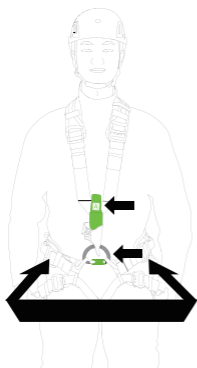

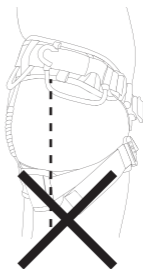
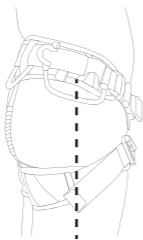
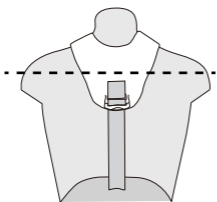

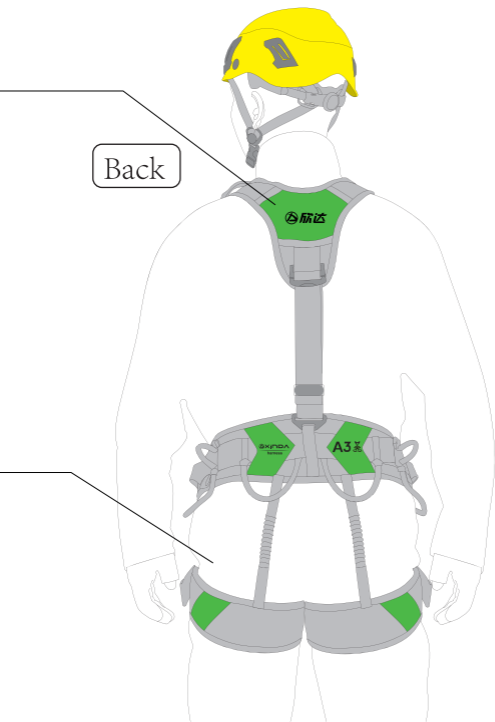

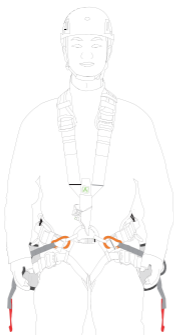
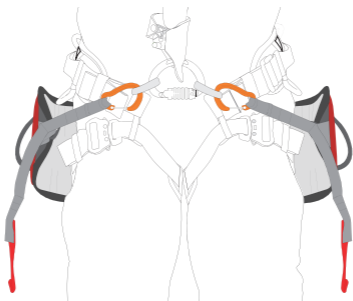

Installing and removing the rope

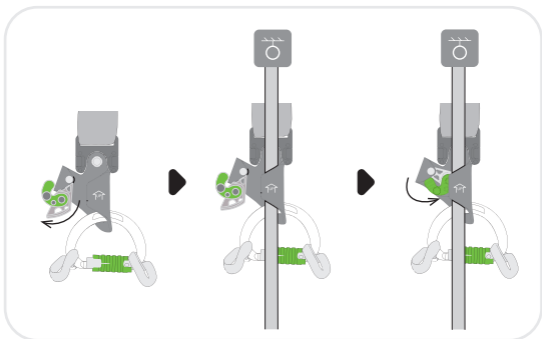

Function principle and test

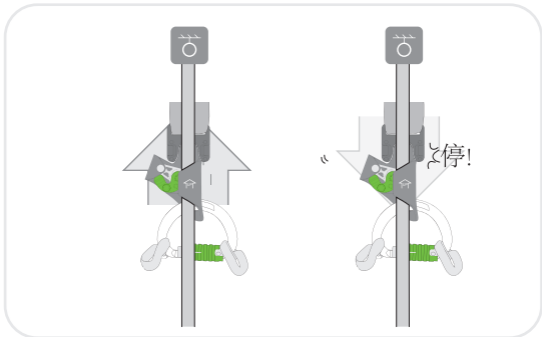

Short rope descent

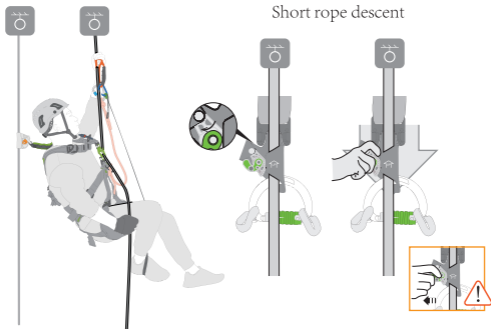

Equipment loops Load

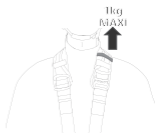
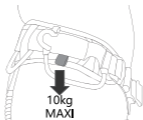
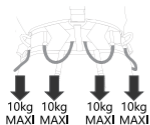

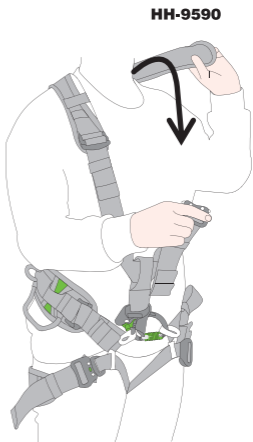
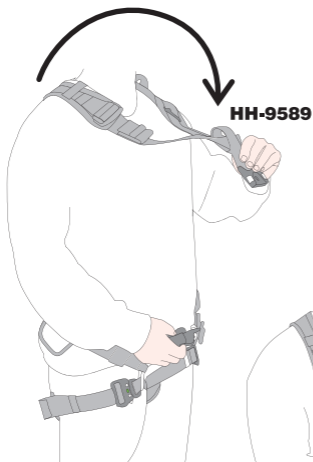

Traceability and marking

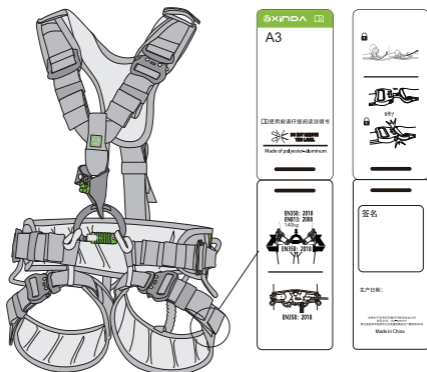

Size

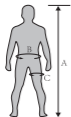

Size	A (cm)	B (cm)	C (cm)
M	165-175cm	74-108cm	45-65cm
L	170-185cm	80-120cm	55-85cm

1. Field of application

Personal protective equipment (PPE) used for fall protection from height.

Lightweight seat harness for rope progression operations.

WARNING: this harness is not suitable for progression using rock climbing techniques; there is a risk of inversion.

Rope access harness with gated ventral point and integrated rope clamp.

Nominal maximum load: 140 kg.

This product must not be pushed beyond its limits, nor be used for any purpose other than that for which it is designed.

Responsibility

WARNING

Activities involving the use of this equipment are inherently dangerous.

You are responsible for your own actions, decisions and safety.

Before using this equipment, you must:

- Read and understand all Instructions for Use.
- Get specific training in its proper use
- Become acquainted with its capabilities and limitations.
- Understand and accept the risks involved.

Failure to heed any of these warnings may result in severe injury or death.

This product must only be used by competent and responsible persons, or those placed under the direct and visual control of a competent and responsible person.

You are responsible for your actions, your decisions and your safety and you assume the consequences of same. If you are not able, or not in a position to assume this responsibility, or if you do not fully understand the instructions for Use, do not use this equipment

2. Nomenclature

Chest harness:

(1) Dorsal strap buckles, (2) Sternal strap buckles, (3) Sternal attachment point, (4) Shoulder fixing loops, (5a) Buckle for connecting the chest ascender, (5b) Chest ascender, (5c) Semicircular connector, (6) Elastic keepers, (7) Fall-arresting lanyard attachment point

Sit harness:

(8) Quick-release buckles (9) Leg loops, (10) Seat attachment point, (11) Waistbelt, (12) Tool bag attachment point, (13) Ventral connector, (13) Side attachment points, (15) Dorsal restraint point, (16) Elastic straps, (17) Gear loops

Principal materials:

- Straps: polyester, adjustment buckles: steel;
- H7: frame: aluminum alloy; cam: steel

3. Inspection, points to verify

Your safety depends upon the integrity of your equipment.

Xinda recommends a detailed inspection by a competent person at least once every 12 months (depending on current regulations in your country, and your conditions of usage).

WARNING: your intensity of use may cause you to inspect your PPE more frequently.

Before each use

Harness

Check the webbing at the attachment points, at the adjustment buckles and at the safety stitching. Be particularly careful to check for cut or loose threads.

Look for cuts, wear and damage due to use, to heat, to chemicals... Verify that the buckles function properly.

Verify the absence of any cracks, deformation, marks, wear, corrosion.

Rope clamp

On the product, verify the absence of any cracks, deformation, marks, wear, corrosion.

Check the condition of the frame, the attachment holes, the cam and safety catch, the springs and the cam axle.

Check the mobility of the cam and the effectiveness of its spring.

Verify that the cam's teeth are not dirty.

During use

Regularly verify that the adjustment buckles are properly tightened. It is important to regularly monitor the condition of the product and its connections to the other equipment in the system.

Make sure that all items of equipment are correctly positioned with respect to each other.

BEWARE:

- Of foreign objects that can impede the operation of the cam.
- Of situations where the safety catch can snag and cause the cam to open.

4. Compatibility

Verify that this product is compatible with the other elements of the system in your application (compatible = good functional interaction).

5. Harness setup

-To fasten the A3, use an EN 362 locking carabiner designed for triaxial loading.

-Be sure to correctly stow the excess webbing (folded flat) in the elastic keepers.

-Beware of foreign objects that could impede the operation of the buckles (e.g. pebbles, sand, clothing...). Verify that they are correctly fastened (see diagrams).

Adjust the position of the point to suit your body type and size

It at the level of the shoulder blades

Adjustment and suspension test

Your harness must be adjusted to fit snugly to reduce the risk of injury in the event of a fall.

In a safe environment, you must move around and hang in the harness from each attachment point, with your equipment, to verify that the harness fits properly, provides adequate comfort for the intended use and that it is optimally adjusted

6. EN 361:2002 fall-arrest harness

Full-body harness the EN 363 standard (personal fall protection systems).

Sternal attachment point

Only these points may be used to attach a fall-arrest system, for example a mobile fall arrester, an energy absorber, or other system described in the EN 363 standard. For ease of identification, these points are marked with the letter 'A'.

Clearance: amount of free space below the user

The free space below the user must be sufficient to prevent the user from hitting an obstacle in the event of a fall.

7. EN 358: 2018 belt for work positioning and restraint

These attachment points must only be used to attach to a restraint or work positioning system

See the instructions for use of the lanyard used, for usage precautions. These attachment points are not designed for fall-arrest usage. Do not use a work positioning belt if there is a foreseeable risk of the user becoming suspended or exposed to uncontrolled tension on the belt. For work positioning, use an anchor point situated at or above waist level. It may be necessary to supplement work positioning or restraint systems with collective or personal fall-arrest systems.

The waist belt is approved for one user, including his/her tools and equipment, for a maximum total weight of 150kg

7A. Gated ventral attachment point

7B. Rear restraint attachment point

This rear waistbelt attachment point is designed only for attachment of a restraint system to prevent the user from entering an area where a fall is possible.

8. EN 813:2008.

Sit harness

Gated ventral attachment point

Designed for progression on rope and work positioning.

Use the ventral point to attach a descender, positioning lanyards or progression lanyard

This attachment point is not suitable for fall arrest.

9. EN 12841:2006 rope clamp

The rope clamp is a type B rope adjustment device used for upward progression on the work rope.

The rope clamp must be used with a type A back-up device on the safety rope (e.g. with an mobile fall arrester for rope).

- The rope clamp is not suitable for use in a fall-arrest system.

-To meet the requirements of the EN 12841:2006 type B standard, use 10-13mm EN 1891 type A low stretch ropes.

-Use a connecting assembly of maximum length 1 meter (lanyard+connectors+devices)

-Do not allow slack in the rope between the rope adjustment device and the anchor, in order to reduce the risk of a fall.

When your body weight is on the work rope, make sure that the safety rope is not loaded.

A dynamic overload can damage the safety rope.

Function principle and test

This rope clamp is a device for ascending rope. It slides along the rope in one direction and blocks in the other direction.

The cam's teeth initiate a clamping action that blocks the rope by pinching it between the cam and the frame. The slot in the cam allows mud to clear.

Installing and removing the rope

Pull the safety catch down and lock it on the frame of the device. The cam is thus held open

Put the rope in the device. Install in the correct direction (UP arrow). Release the safety catch so that the cam presses against the rope. In this position, the safety catch helps prevent involuntary opening of the cam.

To remove the rope, slide the device upwards on the rope while operating the safety catch to disengage the cam.

Rope ascent

Use the rope clamp with another rope clamp and a foot loop. Always attach yourself to the second rope clamp with an appropriate lanyard.

Angled traverse situation

Starting on an angled rope: put a leg over the rope to align it with the rope clamp's rope channel

Short descent

Slide the device slightly up the rope and simultaneously push the cam with your index finger

Do not manipulate the safety catch because there is a risk of accidentally opening the cam.

10. Equipment loops

Equipment loops must only be used for equipment.

WARNING-DANGER: never use equipment loops for belaying, rappelling, tying in, or anchoring a person.

The Velcro keeper may be used to hold your mobile fall arrester's energy absorber in a high position.

11. How to wear

HH-9589 harness equipped with ventral quick-release buckles for easier use

HH-9590 harness equipped with shoulder quick-release buckles for easier use

12. Additional information

This product meets the requirements of Regulation (EU) 2016/425 on personal protective equipment

-You must have a rescue plan and the means to rapidly implement it in case of difficulties encountered while using this equipment

-The anchor point for the system should preferably be located above the user's position and should meet the requirements of the EN 795 standard (minimum strength of 12kN)

-In a fall-arrest system, it is essential to check the required clearance below the user before each use, in order to avoid hitting the ground or an obstacle in case of a fall.

-Make sure that the anchor point is correctly positioned, in order to limit the risk and the length of a fall.

-A fall-arrest harness is the only device allowable for supporting the body in a fall-arrest system

-When using multiple items of equipment, a dangerous situation can arise in which the safety function of an item of equipment can be affected by the safety function of another item of equipment.

-WARNING: ensure that your products do not rub against abrasive or sharp surfaces.

-Users must be medically fit for activities at height. WARNING: insert suspension in a harness can result in serious injury or death.

-The instructions for use for each item of equipment used in conjunction with this product must be followed.

-The instructions for use must be provided to the user of this equipment, in the language of the country where the equipment is used.

-Keep the instructions for use in a permanent file for reference after removing them from the equipment.

-Make sure the markings on the product are legible.

When to retire your equipment:

WARNING: an exceptional event can lead you to retire a product after only one use, depending on the type and intensity of usage and the environment of usage (harsh environments, marine environments, sharp edges, extreme temperatures, chemicals...)

A product must be retired when:

-It has exceeded its lifespan.

-It has been subjected to a major fall or load.

-It fails to pass inspection. You have any doubt as to its reliability.

-You do not know its full usage history (e.g. an illegible product marking).

-When it becomes obsolete due to changes in legislation, standards, technique or incompatibility with other equipment...

Destroy these products to prevent further use.

3-year guarantee

Against any material or manufacturing defect Exclusions: normal wear and tear. Oxidation modifications or alterations, incorrect storage, poor maintenance, negligence, uses for which this product is not designed